

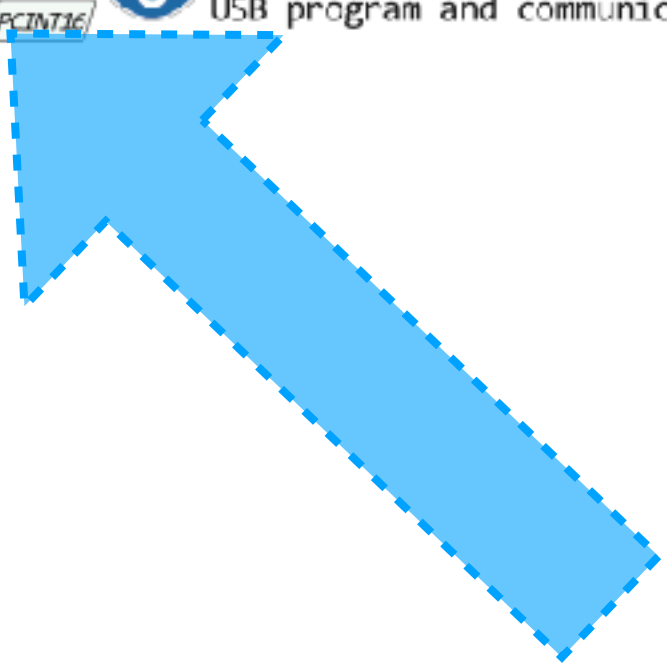

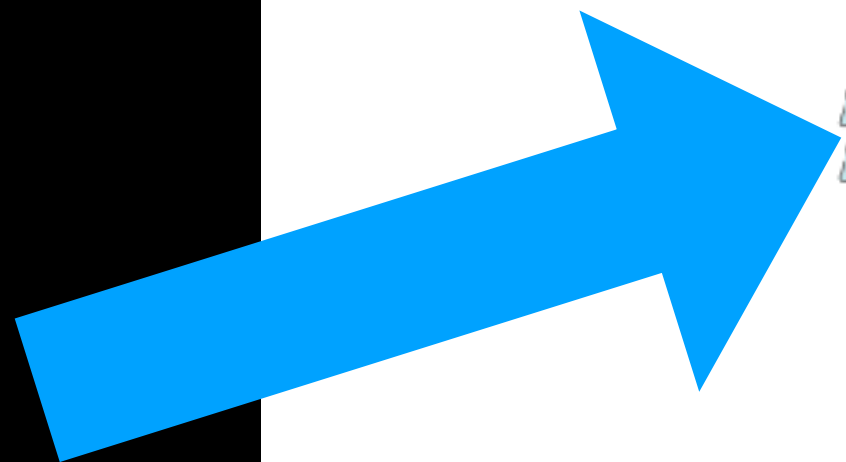

# UNO PINOUT



Arduino can talk to the world three ways

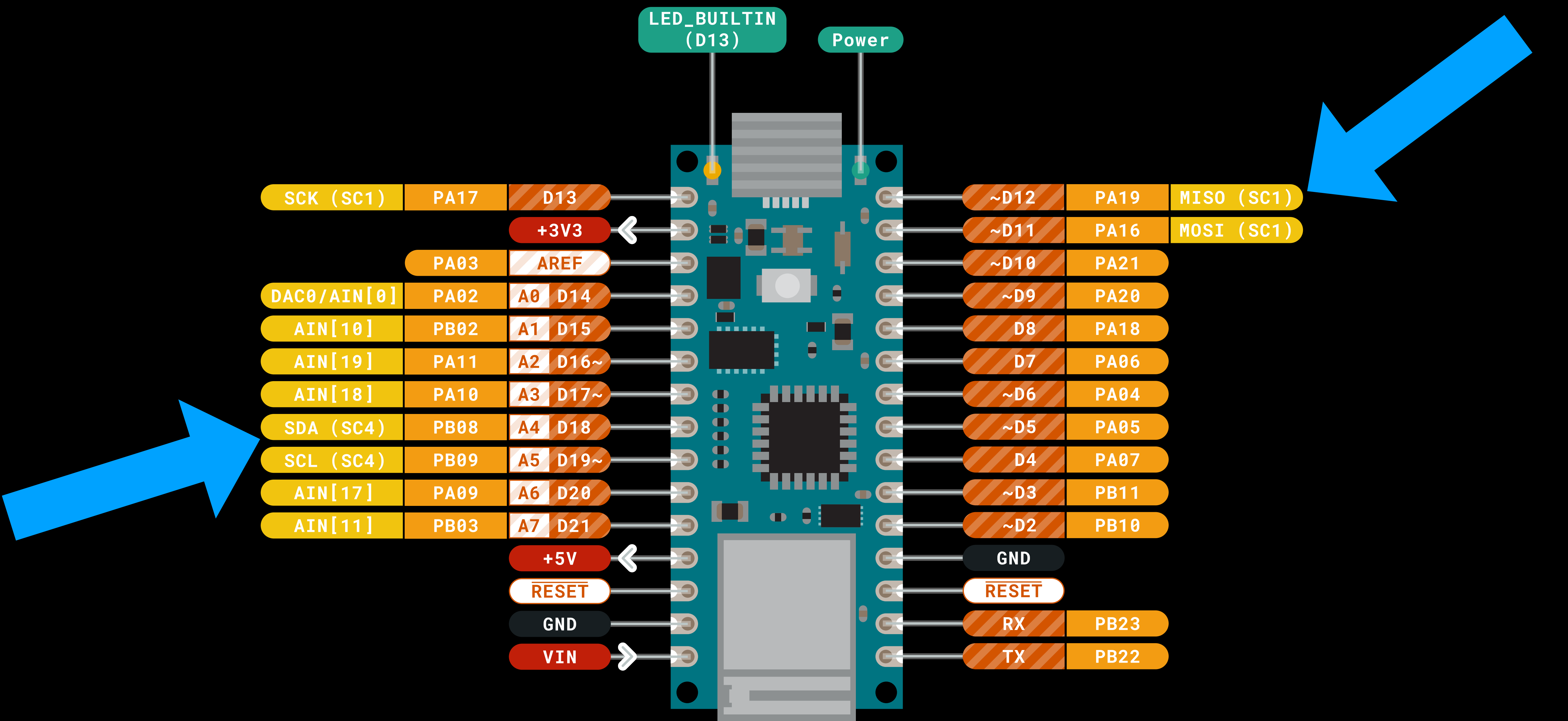

Arduino can talk to the world three ways

# I2C

## Pins

- **SDA** (data)
- **SCL** (clock)

Peripherals have unique address

All peripherals share both wires

**SDA** line is two-way

`Wire.h` library

ToF and OLED in demo

# SPI

## Pins

- **MOSI** (data from  $\mu\text{C}$ )
- **MISO** (data to  $\mu\text{C}$ ,)
- **SCK** (clock)
- **CS** (select, aka SS)

Peripherals selected with **SS**

Each peripheral needs new **SS** line

Separate lines for data direction

`SPI.h` library

(Sharp LCD display in demo)

Legacy language (“Master”/“Slave”) in flux,  
most typical alternative is “Data”, “DIN”, and/  
or “DOUT” with direction inferred from  
context.

# I2C

## Pins

- **SDA** (data)
- **SCL** (clock)

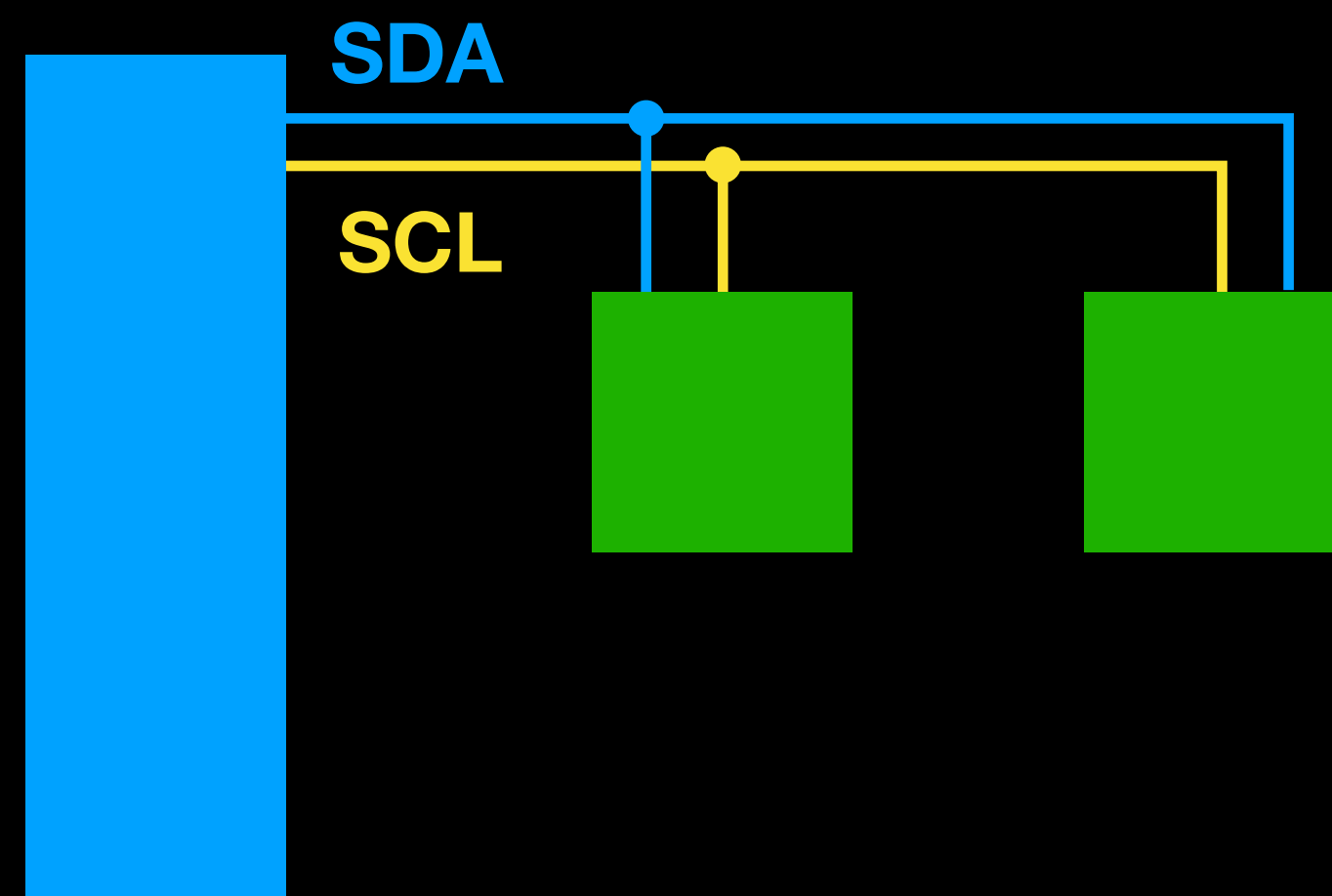

# SPI

## Pins

- **MOSI** (or DOUT, data *from*  $\mu c$ )
- **MISO** (of DIN, data *to*  $\mu c$ ,)
- **SCK** (clock)
- **CS** (select, aka SS)

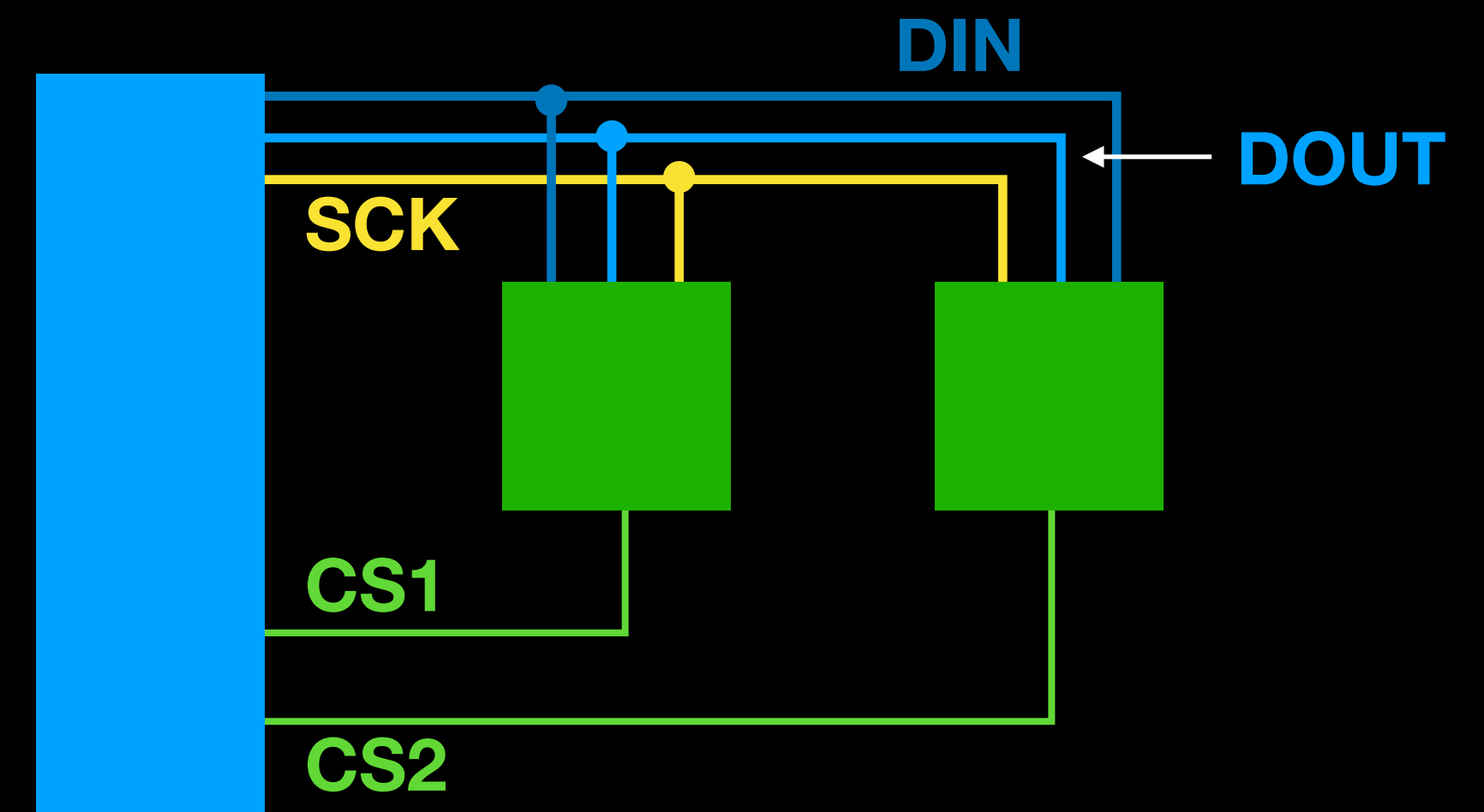



# I2C

Search: Adafruit Industries, U...  
 adafruit.com/?q=I2C

Shop Learn Blog Forums Videos Account

Search: I2C

### Search results for I2C

PRODUCTS | LEARN | BLOG | FORUMS

**I2c / SPI character LCD backpack**  
 PRODUCT ID: 292  
 LCD backpacks reduce the number of pins needed to connect to an LCD. LCDs are a fun and easy way to provide your microcontroller or project talk back to you. Character LCDs are common, and easy to get, available in lots of colors and sizes. We've written tutorials on using character LCDs with an...

ADD TO CART **\$9.95**  
IN STOCK

**I2C Driver by Excamera Labs**  
 PRODUCT ID: 4257  
 I2C Driver is an easy-to-use, open source tool for controlling I2C devices and a great tool to help with quick driver development and debugging. It works with Windows, Mac, and Linux, and has a built-in color screen that shows a live dashboard of all the I2C...

ADD TO CART **\$29.95**  
IN STOCK

**TCA9548A I2C Multiplexer**  
 PRODUCT ID: 277  
 This is a brand name I2C device, and you seem to be using it to connect more than one to your Arduino when you realize "fun" on this chip has a fixed I2C address, and from what I know about I2C, you can't have two devices with the same address in the same I2C bus. Just one you're...

ADD TO CART **\$6.95**  
92 IN STOCK

**Adafruit I2C Non-Volatile FRAM Breakout - 256Kbit / 32KByte**  
 PRODUCT ID: 1030  
 FRAM, or Ferroelectric Ram, is the coolest new data storage method that all the tech magazines are talking about. It's fast, it's like a DRAM, it's non-volatile, but FRAM is pretty damn cool too! It's similar to Dynamic random-access...

ADD TO CART **\$9.95**  
IN STOCK

**Adafruit I2C Controlled + Keypad Shield Kit for 16x2 LCD**  
 PRODUCT ID: 710  
 The new Adafruit shield makes it easy to use a 16x2 Character LCD. The new Character LCD is NDT, repeat. NDT. Includes a really like the range of LCDs we stock in the shop, such as our 16x2, 16x2 & 16x2 with the latest I2C...

ADD TO CART **\$14.95**  
IN STOCK

**MPL3115A2 - I2C Barometric Pressure/Altitude/Temperature Sensor**  
 PRODUCT ID: 1893  
 The pressure sensor from Precision is a great low-cost sensing solution for precision measurement of barometric pressure and altitude. The MPL3115A2 has a typical 1.5 Pascal resolution, which can resolve altitude at 0.3 meters...

ADD TO CART **\$9.95**  
IN STOCK

**MCP23017 - I2C 16 input/output port expander**  
 PRODUCT ID: 737  
 Add another 16 pins to your microcontroller using a MCP23017 port expander. The MCP23017 uses two 8-bit I/Os (these can be shared with other I/O devices), and in exchange gives you 16 general purpose pins. You can set each of 16 pins to be input, output, or input with a pullup. There's even the...

ADD TO CART **\$2.95**  
IN STOCK

**MPL115A2 - I2C Barometric Pressure/Temperature Sensor**  
 PRODUCT ID: 992  
 The pressure sensor from Precision is a great low-cost sensing solution for measuring barometric pressure. At 1.5 hPa resolution, it's not as precise as our serial pressure sensor, the BMP280 series, which has up to 0.05 hPa...

ADD TO CART **\$7.95**  
IN STOCK

**MCP23008 - I2C 8 input/output port expander**  
 PRODUCT ID: 595  
 Add another 8 pins to your microcontroller using a MCP23008 port expander. The MCP23008 uses two 4-bit I/Os (these can be shared with other I/O devices), and in exchange gives you 8 general purpose pins. You can set each of 8 pins to be input, output, or input with a pullup. There's even the...

ADD TO CART **\$1.95**  
IN STOCK

**Adafruit BME280 I2C or SPI Temperature Humidity Pressure Sensor**  
 PRODUCT ID: 2852  
 We've just stepped up their game with their new BME280 sensor, an environmental sensor with temperature, barometric pressure and humidity. This sensor is great for all sorts of weather/environmental sensing and can...

ADD TO CART **\$19.95**  
IN STOCK

**CATEGORIES**

- Electronics
- Beats
- Raspberry Pi
- Arduino
- Arduino boards
- CircuitPython
- Formal & A Parts
- GPIO - Creative Kits
- Development Boards
- Hardware
- Internet of Things - IoT
- Kits & Projects
- LEDs
- LEDs & Displays
- Power
- Prototyping
- Robotics & CNC
- Sensors
- STEMMA
- Tools
- Wireless
- Wireless

**AVAILABILITY**

- In Stock
- Out Of Stock
- Discontinued

# SPI

Search: Adafruit Industries, U...  
 adafruit.com/?q=SPI

Shop Learn Blog Forums Videos Account

Search: SPI

### Search results for SPI

PRODUCTS | LEARN | BLOG | FORUMS

**SPIDriver by Excamera Labs**  
 PRODUCT ID: 4258  
 SPIDriver is an easy-to-use tool for controlling SPI devices and a great tool to help with quick driver development and debugging. It works with Windows, Mac, and Linux, and has a built-in color screen that shows a live dashboard display of all the SPI devices it uses a standard I2C USB...

ADD TO CART **\$29.95**  
90 IN STOCK

**I2c / SPI character LCD backpack**  
 PRODUCT ID: 292  
 LCD backpacks reduce the number of pins needed to connect to an LCD. LCDs are a fun and easy way to provide your microcontroller or project talk back to you. Character LCDs are common, and easy to get, available in lots of colors and sizes. We've written tutorials on using character LCDs with an...

ADD TO CART **\$9.95**  
IN STOCK

**Adafruit SPI Non-Volatile FRAM Breakout - 64Kbit / 8KByte**  
 PRODUCT ID: 1887  
 FRAM, or Ferroelectric Ram, is the coolest new data storage method that all the tech magazines are talking about. It's fast, it's like a DRAM, it's non-volatile, but FRAM is pretty damn cool too! It's similar to Dynamic random-access...

ADD TO CART **\$5.95**  
IN STOCK

**CD DVD Spindle Motor**  
 PRODUCT ID: 3832  
 We've just stepped up their game with their new CD/DVD spindle motor. These motor parts made a CD or DVD player that turns into a nice and ready fast. These motors have some great benefits that make them easier to use than the standard style that you can find...

NOTIFY ME **\$1.95**  
OUT OF STOCK

**Monochrome 128x32 SPI OLED graphic display**  
 PRODUCT ID: 561  
 These displays are small, only about 1" diagonal, but very readable due to the high contrast of an OLED display. This display is made of 128x32 individual white OLED pixels, each one is turned on or off by its controller chip, because the display makes its own light, no backlight is required...

ADD TO CART **\$17.50**  
IN STOCK

**Adafruit Bluefruit LE SPI Friend - Bluetooth Low Energy (BLE)**  
 PRODUCT ID: 2638  
 We'll get the best of a world with our new Bluefruit LE SPI Friend. It's a tiny little board, fit for other electronics projects, packed with BLE now included in modern smart phones and tablets. It's fun to add wireless connectivity. So what...

ADD TO CART **\$17.50**  
214 IN STOCK

**Adafruit BME280 I2C or SPI Temperature Humidity Pressure Sensor**  
 PRODUCT ID: 2852  
 We've just stepped up their game with their new BME280 sensor, an environmental sensor with temperature, barometric pressure and humidity. This sensor is great for all sorts of weather/environmental sensing and can...

ADD TO CART **\$19.95**  
IN STOCK

**Adafruit BMP280 I2C or SPI Barometric Pressure & Altitude Sensor**  
 PRODUCT ID: 2851  
 Bosch has stepped up their game with their new BMP280 sensor, an environmental sensor with temperature, barometric pressure and humidity. This sensor is great for all sorts of weather/environmental sensing and can...

ADD TO CART **\$9.95**  
IN STOCK

**1.8" SPI TFT display, 160x128 18-bit color - ST7735R driver**  
 PRODUCT ID: 816  
 We've just stepped up their game with their new 1.8" TFT display, with 160x128 pixels (up to 18-bit per pixel), 160x128 resolution, two white LED backlight that runs on 2.5V and a very easy SPI interface that requires only 4 or 5 digital pins to send pixels to...

ADD TO CART **\$9.95**  
20 IN STOCK

**MCP3008 - 8-Channel 10-Bit ADC With SPI Interface**  
 PRODUCT ID: 855  
 Need to add analog inputs? This chip will add 8 channels of 10-bit analog input to your microcontroller or microcontroller project. It's super easy to use, and uses SPI so only 4 pins are required. We chose this chip at a great price to make it fun to use...

ADD TO CART **\$3.75**  
IN STOCK

**CATEGORIES**

- Electronics
- Beats
- Raspberry Pi
- Arduino
- Arduino boards
- CircuitPython
- Formal & A Parts
- GPIO - Creative Kits
- Development Boards
- Hardware
- Internet of Things - IoT
- Kits & Projects
- LEDs
- LEDs & Displays
- Power
- Prototyping
- Robotics & CNC
- Sensors
- STEMMA
- Tools
- Wireless
- Wireless

**AVAILABILITY**

- In Stock
- Out Of Stock
- Discontinued



# I2C

sparkfun.com/search/results?term=I2C

sparkfun START SOMETHING SHOP LEARN BLOG SUPPORT

PRODUCT MENU I2C

HOME / SEARCH RESULTS FOR I2C

## 5459 Results for "I2C"

PRODUCTS 2374 TUTORIALS 837 BLOG 2088 RESOURCES 180

Related Categories  
Qwiic, Series 2 (ZigBee), 2-axis

**SORT BY:**  
 Relevance  
 Highest Price  
 Lowest Price  
 Alphabetical  
 Newest  
 Oldest

**CUSTOMER REVIEWS:**  
 ★★★★★  
 ★★★★★ & Up  
 ★★★★★ & Up  
 ★★★★★ & Up  
 ★★★★★ & Up  
 ★★★★★ & Up  
 All Ratings

**PRICE:**  
 All prices  
 \$0 - \$10  
 \$10 - \$20  
 \$20 - \$30  
 \$30 - \$40  
 \$40 - \$50  
 \$50 - \$75  
 \$75 - \$100  
 \$100 +

<b>I2C EEPROM - 256k Bit (24LC256)</b> COM-00525 \$1.95 ★★★★★ 1	<b>SparkFun Differential I2C Breakout - PCA9615 (Qwiic)</b> BOB-14589 \$10.95 ★★★★★ 7	<b>I2C DRIVER</b> DEV-15457 \$32.95 ★★★★★ 1	<b>LinkM - USB to I2C</b> COM-05903 \$29.95
<b>SparkFun I2C DAC Breakout - MCP4725</b> BOB-12918 \$4.95 ★★★★★ 4	<b>BlinkM - I2C Controlled RGB LED</b> COM-06079 \$12.95 ★★★★★ 2	<b>BlinkM MaxM - I2C Controlled RGB LED</b> COM-09000 \$24.95 ★★★★★ 2	<b>SparkFun Qwiic Adapter</b> DEV-14495 \$1.50
<b>Qwiic Button - Blue</b> SPX-15585 \$3.95	<b>Qwiic Switch</b> SPX-15585 \$3.95	<b>Qwiic Button - Red</b> SPX-15584 \$3.95	<b>Qwiic Arcade - Red</b> SPX-15591 \$5.95
<b>Qwiic Arcade - Blue</b> SPX-15592 \$5.95	<b>SparkFun Micro OLED Breakout (Qwiic)</b> LCD-14532 \$16.95 ★★★★★ 2	<b>Qwiic Thermocouple Amplifier - MCP9600</b> SPX-15508 \$19.95	<b>SparkFun Qwiic Keypad - 12 Button</b> COM-15290 \$9.95 ★★★★★ 2
<b>SparkFun Qwiic Shield for Arduino</b> DEV-14357 \$19.95	<b>SparkFun Qwiic Quad Relay</b> COM-15100 \$19.95	<b>SparkFun GPS Breakout - XA1110 (Qwiic)</b> COM-15110 \$19.95	<b>SparkFun Qwiic Single Relay</b> COM-15093 \$19.95

# SPI

sparkfun.com/search/results?term=SPI

sparkfun START SOMETHING SHOP LEARN BLOG SUPPORT

PRODUCT MENU SPI

HOME / SEARCH RESULTS FOR SPI

## 517 Results for "SPI"

PRODUCTS 204 TUTORIALS 224 BLOG 77 RESOURCES 12

**SORT BY:**  
 Relevance  
 Highest Price  
 Lowest Price  
 Alphabetical  
 Newest  
 Oldest

**CUSTOMER REVIEWS:**  
 ★★★★★  
 ★★★★★ & Up  
 ★★★★★ & Up  
 ★★★★★ & Up  
 ★★★★★ & Up  
 All Ratings

**PRICE:**  
 All prices  
 \$0 - \$10  
 \$10 - \$20  
 \$20 - \$30  
 \$30 - \$40  
 \$40 - \$50  
 \$50 - \$75  
 \$75 - \$100  
 \$100 +

<b>SPI Buffer Saver</b> SPX-14923 \$2.95	<b>SPI Driver Core</b> DEV-15456 \$31.95	<b>LCD Touchscreen HAT for Raspberry Pi - TFT 3.5in. (480x320)</b> LCD-14776 \$24.95 ★★★★★ 2	<b>Bus Pirate - v3.6a</b> ICE-17940 \$29.95 ★★★★★ 14
<b>SparkFun Flexible Grayscale OLED Breakout - 1.81"</b> LCD-14806 \$50.95	<b>SparkFun TFT LCD Breakout - 1.8" (128x160)</b> LCD-15148 \$29.95	<b>USB Logic Analyzer - 25MHz/8-Channel</b> TOL-15035 \$19.95 ★★★★★ 2	<b>Real Time Clock - DS3234</b> COM-10079 \$9.95
<b>SparkFun Triple Axis Accelerometer Breakout - HSLIS331DL</b> SEN-14960 \$11.95	<b>SparkFun DeadOn RTC Breakout - DS3234</b> BOB-10150 \$20.95 ★★★★★ 1A	<b>Pixhawk 4 Flight Controller</b> BOB-15461 \$249.95 ★★★★★ 1	<b>SparkFun 16x2 SerLCD - RGB on Black 3.3V</b> LCD-14073 \$19.95 ★★★★★ 1
<b>SparkFun Triple Axis Magnetometer Breakout - MLX90393 (Qwiic)</b> SEN-14571 \$14.95	<b>SparkFun Transparent Graphical OLED Breakout (Qwiic)</b> LCD-15173 \$39.95 ★★★★★ 2	<b>SparkFun gator:bit</b> DEV-14494 \$20.95	<b>SparkFun 16x2 SerLCD - Black on RGB 3.3V</b> LCD-14072 \$19.95 ★★★★★ 4
<b>SparkFun 20x4 SerLCD - Black on RGB 3.3V</b> LCD-14074 \$24.95 ★★★★★ 3	<b>SparkFun VR IMU Breakout - BNO080 (Qwiic)</b> SEN-14566 \$34.95	<b>SparkFun 9DoF IMU Breakout - LSM9DS1</b> SEN-13291 \$15.95 ★★★★★ 10	<b>SparkFun gator:bit v2.0 - micro:bit Carrier Board</b> DEV-15162 \$19.95



# I2C

# SPI

Search: Artificial Industries, U... Search Results for I2C - Spark... I2C Environmental Sensors | M...

mouser.com/Sensors/Environmental-Sensors/\_/N-axr11?Keyword=I2C&FS=True

Products - Manufacturers Services & Tools Technical Resources Help Account & Orders

All Products > Sensors > Environmental Sensors

Show other information about "I2C" See related content >

### I2C Environmental Sensors

Products (122) Datasheets (44) Images (48) Newest Products

Types of Environmental Sensors | List View

- Air Quality Sensors (4)
- Board Mount Humidity Sensors (110)
- Industrial Humidity Sensors (6)

Results: 122 | Smart Filtering

Applied Filters: Sensors Environmental Sensors

Manufacturer: -- Most Popular --  
Sensirion, Honeywell, Silicon Laboratories, Texas Instruments, Amphenol, TE Connectivity, ALPS, Amphenol

Product Type: Air Quality Sensors, Humidity Sensors

Packaging: Bulk, Cut Tape, MouseReel, Reel, Tray, Tube

Reset All Apply Filters

I2C

In Stock  Active  RoHS Compliant  
 Normally Stocked  New Products

Buy Selected Compare Selected (up to 20) Download Table

Select	Image	Part #	Mfr.	Description	Datasheet	Availability	Pricing (USD)	Qty.
<input type="checkbox"/>		Mfr. Part # 92C-HUTMP Mouser Part # 992-92C-HUTMP	Grainger	Industrial Humidity Sensors I2C Humidity and Temperature Sensor	<a href="#">Datasheet</a>	2 In Stock	1: \$26.95	Min: 1 Mult: 1
<input type="checkbox"/>		Mfr. Part # VICS-V2-8ATE Mouser Part # 523-MICS-V2-8ATE	Amphenol SGX Sensortech	Air Quality Sensors I2C Output VOC Module <a href="#">Learn More</a>	<a href="#">Datasheet</a>	213 In Stock	1: \$25.15 5: \$29.00 10: \$21.71 25: \$20.00 50: View	Min: 1 Mult: 1
<input type="checkbox"/>		Mfr. Part # SHTCS Mouser Part # 403-SHTCS	Sensirion	Board Mount Humidity Sensors Humidity and Temperature Sensor <a href="#">Learn More</a>	<a href="#">Datasheet</a>	13,469 In Stock	Cut Tape 1: \$2.66 10: \$2.25 100: \$1.80 500: \$1.57 Reel 2,500: \$1.21 5,000: View	Min: 1 Mult: 1 Reel: 2,500
<input type="checkbox"/>		Mfr. Part # HDC200DMBR Mouser Part # 696-HDC200DMBR	Texas Instruments	Board Mount Humidity Sensors A 955-HDC200DMBT <a href="#">Learn More</a>	<a href="#">Datasheet</a>	12,756 In Stock	Cut Tape 1: \$3.09 10: \$2.72 100: \$2.23 250: \$2.09 Reel	Min: 1 Mult: 1 Reel: 3,000

Search: Artificial Industries, U... Search Results for I2C - Spark... SPI Honeywell Board Mount Humidity Sensors

mouser.com/Sensors/Environmental-Sensors/\_/N-axr11?Keyword=SPI&FS=True

Products - Manufacturers Services & Tools Technical Resources Help Account & Orders

All Products > Sensors > Environmental Sensors > Board Mount Humidity Sensors

Show other information about "SPI" See related content >

### SPI Honeywell Board Mount Humidity Sensors

Authorized Distributor

Products (16) Datasheets (4) Images (7) Newest Products

Results: 16 | Smart Filtering

Applied Filters: Sensors Environmental Sensors Board Mount Humidity Sensors

RH Accuracy: +/- 2%, +/- 3%, +/- 4%, +/- 4.5%

Full Temp Accuracy: +/- 0.3 C, +/- 1 C

Operating Supply Current: 850 uA, 750 uA

Minimum Operating Temperature: -40 C, -26 C

Maximum Operating Temperature: + 65 C, + 100 C

Packaging: Cut Tape, MouseReel, Reel

Reset All Apply Filters

SPI

In Stock  Active  RoHS Compliant  
 Normally Stocked  New Products

Buy Selected Compare Selected (up to 20) Download Table

Select	Image	Part #	Mfr.	Description	Datasheet	Availability	Pricing (USD)	Qty.
<input type="checkbox"/>		Mfr. Part # H181-31-000-001 Mouser Part # 786-H181-31-000-001	Honeywell	Board Mount Humidity Sensors SOIC 8 SMD w/Filter Resists Condensation	<a href="#">Datasheet</a>	669 In Stock	Cut Tape 1: \$11.49 10: \$6.40 25: \$7.50 100: \$7.02 250: View Reel 1,000: \$6.20	Min: 1 Mult: 1 Reel: 1,000
<input type="checkbox"/>		Mfr. Part # H171-31-000-001 Mouser Part # 746-H171-31-000-001	Honeywell	Board Mount Humidity Sensors SPI 3% RH SOIC8 Condensation Filtered <a href="#">Learn More</a>	<a href="#">Datasheet</a>	506 In Stock	1: \$6.94 10: \$7.41 25: \$6.61 100: \$5.81 1,000: View	Min: 1 Mult: 1
<input type="checkbox"/>		Mfr. Part # H161-31-000-001 Mouser Part # 709-H161-31-000-001	Honeywell	Board Mount Humidity Sensors SP 1.4% RH SOIC-8 SMD-Hydrophobic Filter <a href="#">Learn More</a>	<a href="#">Datasheet</a>	215 In Stock	Cut Tape 1: \$11.79 10: \$9.81 25: \$8.89 100: \$8.07 500: View Reel 1,000: \$7.76	Min: 1 Mult: 1 Reel: 1,000
<input type="checkbox"/>		Mfr. Part # H171-30-000-001 Mouser Part # 785-H171-30-000-001	Honeywell	Board Mount Humidity Sensors SOIC 8SMD w/Filter Non-condensing	<a href="#">Datasheet</a>	400 In Stock	Cut Tape 1: \$6.52 10: \$6.27 25: \$6.06 100: \$5.21 Reel 1,000: \$4.63 2,000: View	Min: 1 Mult: 1 Reel: 1,000